

# ***CICADA 180***

## **QUICK START GUIDE**

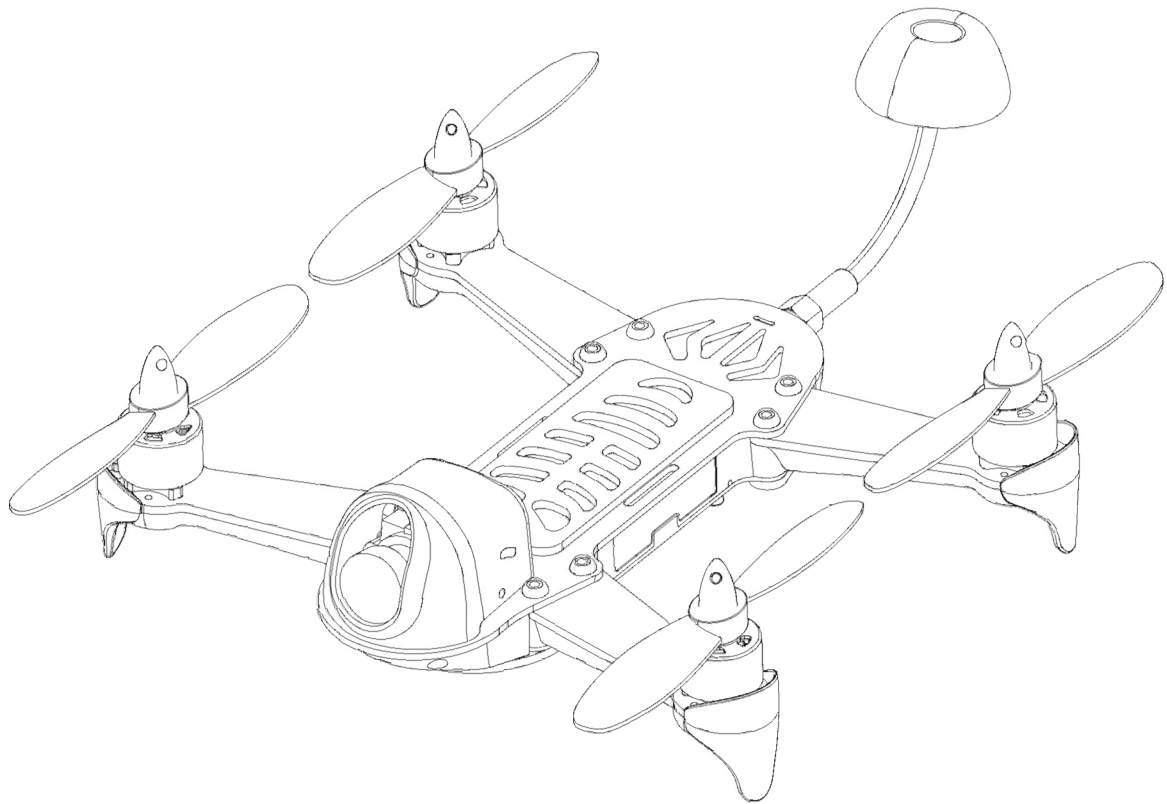
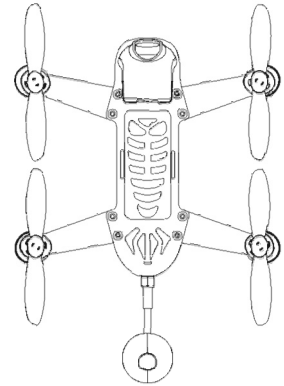

## Contents

1. Knowing your aircraft .....	1
2. Specifications .....	2
3. Connectors and Switches .....	3
4. VTX Specifications .....	4
5. Flight Modes .....	6
6. Knowing your remote controller.....	6
7. OSD(On Screen Display).....	8
8. Firmware Upgrades .....	8
9. Charging .....	9
10. Notes for flight .....	9

# 1. Knowing your aircraft

- The quad frame is made of high strength carbon fiber and plastic component with nice overall appearance and smooth compact assembly. It is solid enough to resist the impact of quads collision. The individual quad arms help reduce maintenance cost.
- The equipped 5.8GHz real-time video transmitter can bring you a whole new experience of first person view.
- Feel free to experience free styles like flips and rolls, as well as racing.

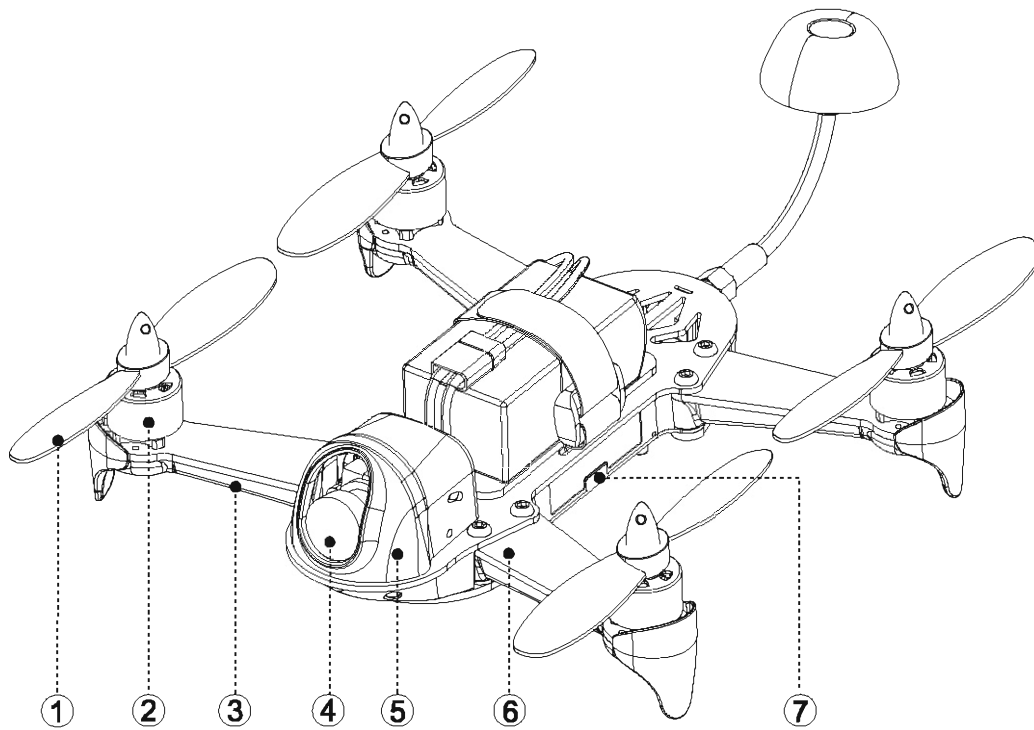

- ① Standard propeller
- ② Motor
- ③ Plastic hybrid
- ④ Camera
- ⑤ Camera cover
- ⑥ Flat CF Arms
- ⑦ USB port
- ⑧ 5.8G antenna
- ⑨ Status indicator
- ⑩ Non-slip pad for battery
- ⑪ Li-Po battery
- ⑫ VTX button

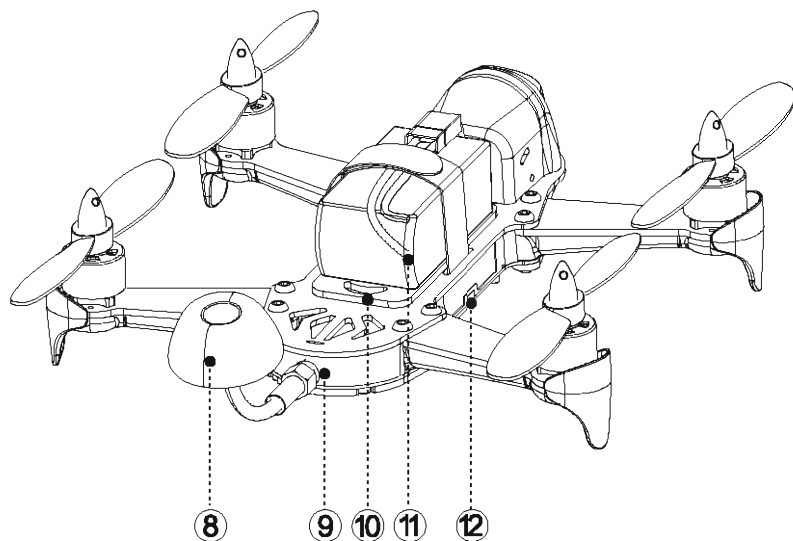

## 2. Specifications

Model	Base	Advanced	note
Size	180mm	180mm	
Frame	2mm CF, with Al- Standoffs	2mm CF, with Al- Standoffs	
Arms	2mm Flat CF/Plastic Hybrid	2mm Flat CF/Plastic Hybrid	
<b>Flight controller</b>			
CPU	STM32F303(F3)	STM32F405(F4)	
IMU	Invensense 6050	Invensense 6000	
Altimeter	/	BM280	
Firmware	Betaflight_3.2.2_SPRACINGF3	Betaflight_3.2.2_OMNIBUSF4SD	
OSD	/	Betaflight OSD	
Black box	8M	/	
RX Support	PPM, SBUS	PPM, SBUS, DSM, IBUS	
<b>VTX</b>			
Frequency	5645 – 5925MHz	5645 – 5925MHz	
Power(mW)	25,200,500,800	25,200,500,800	Adjustable
Band	5	5	A,B,E,F,R
Channels	40	40	8CH/Band
Display	LED Display	LED Display	CH,Band, Power
Set	Button	Support smart audio/button	CH,Band, Power
Pit mode	/	Support	
Antenna	Integrated	Cloverleaf antenna	
<b>Power train</b>			
Motors	Custom 1306 3100kv	Custom 1407 3500kv	
Propeller	4045 / 3x4.5x3	4045 / 4x4.5x3	
Battery	850mAh 3S 40C	450~850mAh 3S/4S 40C~75C	
Battery Connector	XT-30	XT-30	
ESC features	16A/20A Pwm,Oneshot42/125, Dshot150-600	16A/20A Pwm,Oneshot42/125, Dshot150-600	

Model	Base	Advanced	note
<b>Other</b>			
Flight cam	700TVL CMOS	700TVL CMOS	960*576
LED Board	Integrated in PDB	Integrated in PDB	
Lost model beeper	YES	YES	
Weight	<190g(without battery)	<220g/(without battery)	
Flight time	Highly dependent upon battery, and flying style, 3-4 mins typical		

### 3. Connectors and Switches

(1) **BOOT button**

Be used in the bootloader and firmware upgrade.

(2) **USB connector**

Be used to configure the flight controller and upgrade the firmware with Betaflight/Cleanflight.

(3) **VTX button**

To adjust the CH, Band and Power level for the VTX.

(4) **Flight Camera Video/Power Connector**

The flight camera video and power connector is a 3-pin Picoblade connector located at the back of the flight camera. The connector can be easily accessed without disassembling the quad Please refer to the pinout is as follows:

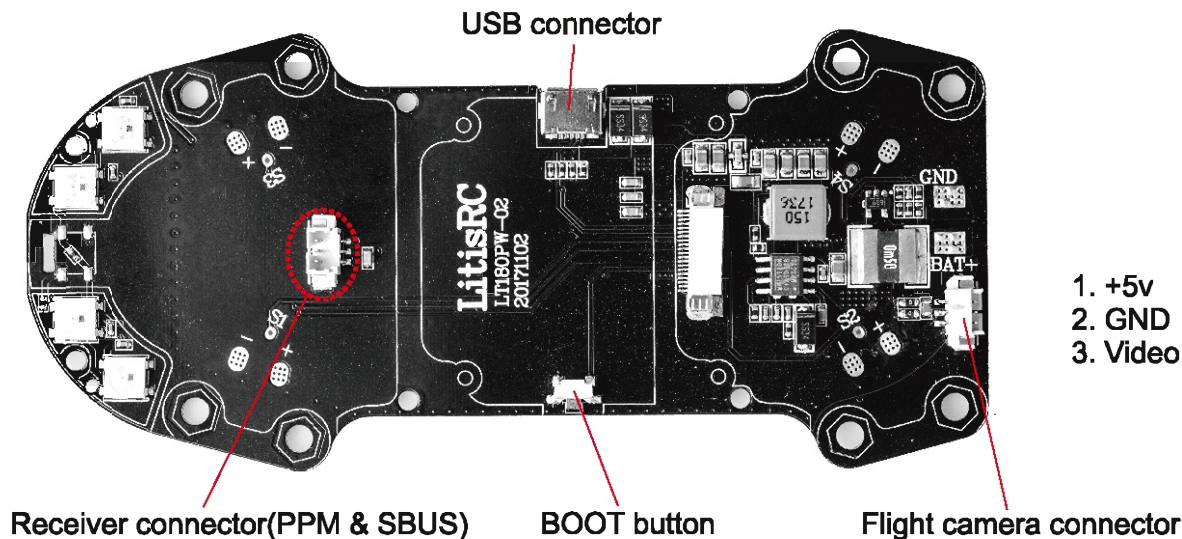

## (5) Receiver

### ■ PPM /SBUS

When using a classic PPM receiver, use the PPM connector, a 3-pin JST-PH connector with the following pinout, refer to "LT180PW-02" receiver connector.

- (1) PPM/SBUS
- (2) +5V Power to the receiver
- (3) GND

### ■ DSM/DSM2 ( UART1 )

- (1) DSM2
- (2) GND
- (3) 3.3V

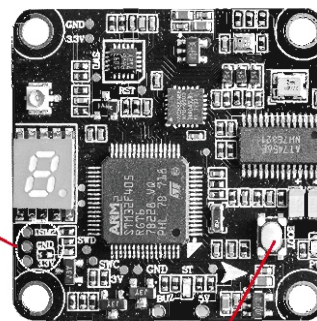

BOOT button

**180BASE :** Please solder the pad according to the receiver(PPM/SBUS), refer to below picture:

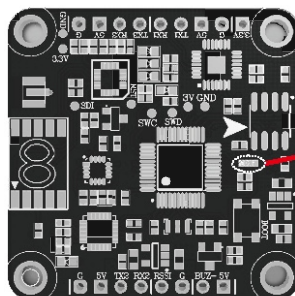

Left : SBUS  
Right : PPM

### Note:

**For BASE 180, please choose the UART 3 when using the SBUS receiver.**

Identifier	Configuration/MSP	Serial Rx	Telemetry Output
UART1	<input type="checkbox"/> 115200 ▾	<input type="checkbox"/>	Disabled ▾ AUTO ▾
UART2	<input type="checkbox"/> 115200 ▾	<input type="checkbox"/>	Disabled ▾ AUTO ▾
UART3	<input type="checkbox"/> 115200 ▾	<input checked="" type="checkbox"/>	Disabled ▾ AUTO ▾

## 4. VTX Specification

### Key Features

- (1) Support Pitmode
- (2) 25mW, 200mW, 500mW and 800mW power switchable
- (3) One button frequency and power setup
- (4) Support Smart Audio ( UART3 )

## Button control Channel select mode

### ■ Channel select mode

Select channels by simple short presses.

### ■ Band select mode

Press button for 2s, LED will flash, then short presses to select band.

### ■ Power select mode

Press button for 4s. LED will flash, then select power by simple short presses.

"1" stands for "25mW" "2" stands for "200mW" "3" stands for "500mW"

"4" stands for "800mW"

The LED will display "channel" "band" "power" successively after setting.

### Note:

**LED flash 2 times quickly while displaying power,  
For example: "1" flash 2 times means "25mW"**

## PitMode

While the VTX is in PitMode, the LED will show "P" and flash. While in PitMode you can change channels and set power levels, with the button, but none of these changes will take effect until you quit PitMode. By default, PitMode will send a very weak signal.

## Exit PitMode

Two ways to exit PitMode:

Press button for 12 seconds to exit PitMode and the LED will show Channel, Band and Power alternately. Turn "Race" to "Free" below the "OP Model" sub-category on OSD display and power to reboot.

## Menu Table

Channel	1	2	3	4	5	6	7	8	
Band	A	B	E	F	R				
Power Level	25	200	500	800					mW

## Frequency Table

Channel	1	2	3	4	5	6	7	8	
Band A	5865	5845	5825	5805	5785	5765	5745	5725	MHZ
Band B	5733	5752	5771	5790	5809	5828	5847	5866	MHZ
Band E	5705	5685	5665	5645	5885	5905	5925	5945	MHZ
Band F	5740	5760	5780	5800	5820	5840	5860	5880	MHZ
Race Band	5658	5695	5732	5769	5806	5843	5880	5917	MHZ
Power Level	25	200	500	800					mW

**Note : 5645/5925/5945 are not available due to FCC regulations.**



## 5. Flight Modes

Three flight modes are configured in the factory, and are mapped by default to channel 6 of the R/C TX. These modes are as follows:

(1) Acro mode is the ideal mode to have fun with flips and rolls.

(2) Angle mode is the easiest to learn. When the sticks are in center, the flight controller is always working to balance the quad. The deviation of the Roll/Pitch controls from neutral defines the angle of the quad in flight. Not a great mode for racing, but definitely the mode to use for the maiden flight.

(3) Horiz mode is a bit of a hybrid mode. It does auto-level, but also allows flips.

### Note:

Acro mode is the preferred mode for the more advanced mini-quad pilots. In many ways it is the simplest mode, but also the hardest mode to learn. In Acro mode, the accelerometer part of the IMU is not used, only the Gyro. Because of this, the quad will not self-level, explaining the steep learning curve for this mode. To learn this mode, it is recommended to start flying the quad FPV, in Angle mode, get some altitude, and switch into Acro mode. Landings in Acro mode can be a bit challenging for beginner, so switching to Angle mode before landing is a reasonable way to deal with this. ( Users can customize the switches fuction of transmitter as well as the flight mode of quad )

## 6. Knowing your remote controller

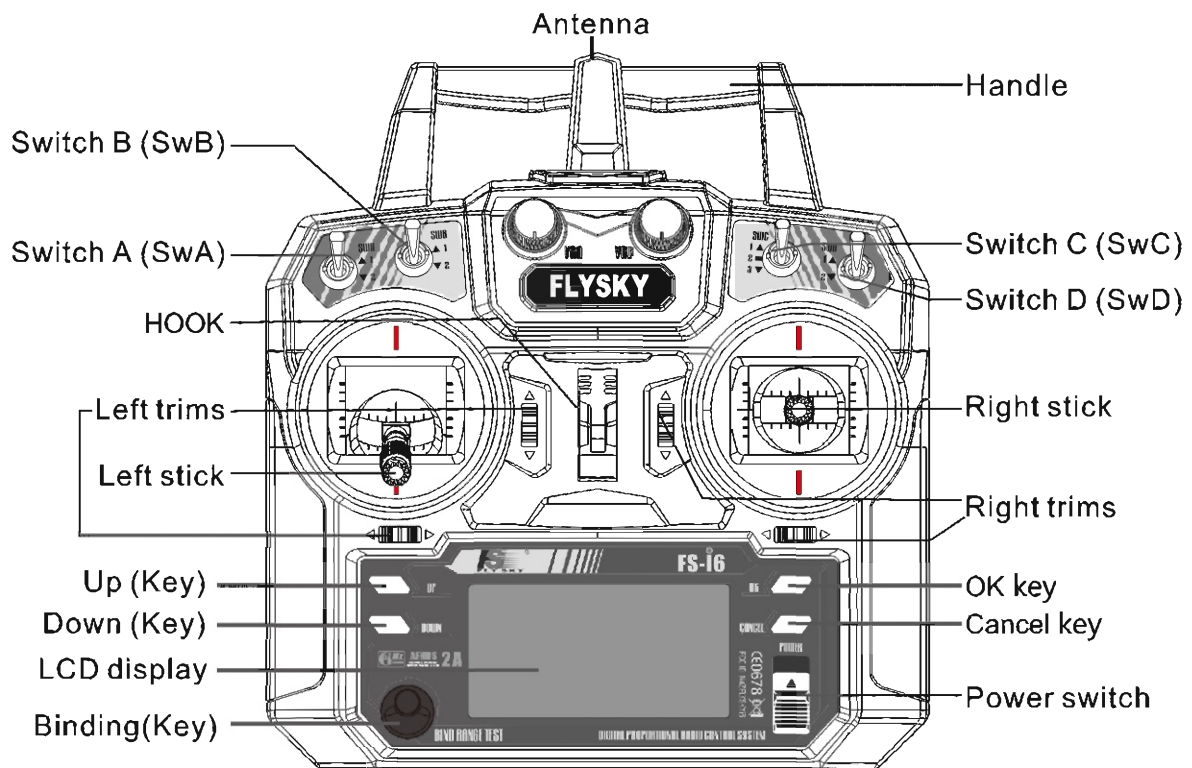



Take "Mode 2" as an example. The left rocker controls the Race Done altitude and leading, while the right rocker controls its forward\backward\left\right movements.

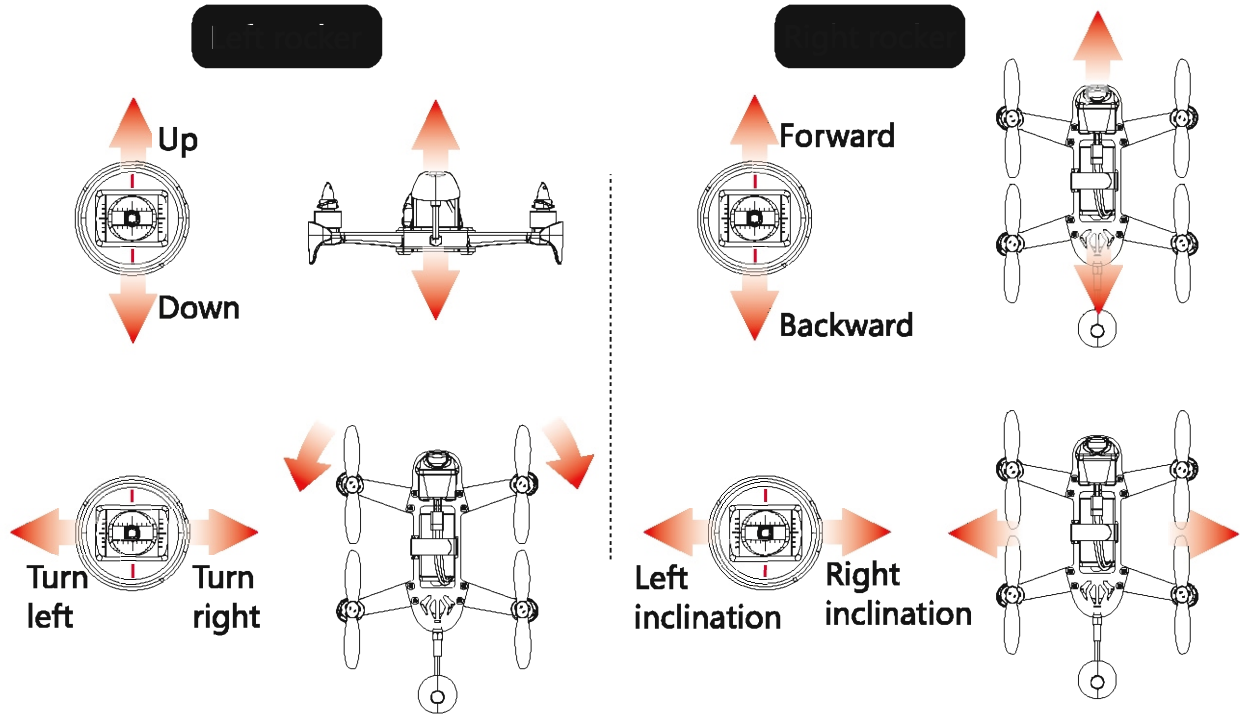

## Flight Controller Stick Commands

### ▪ Arm Flight Controller:

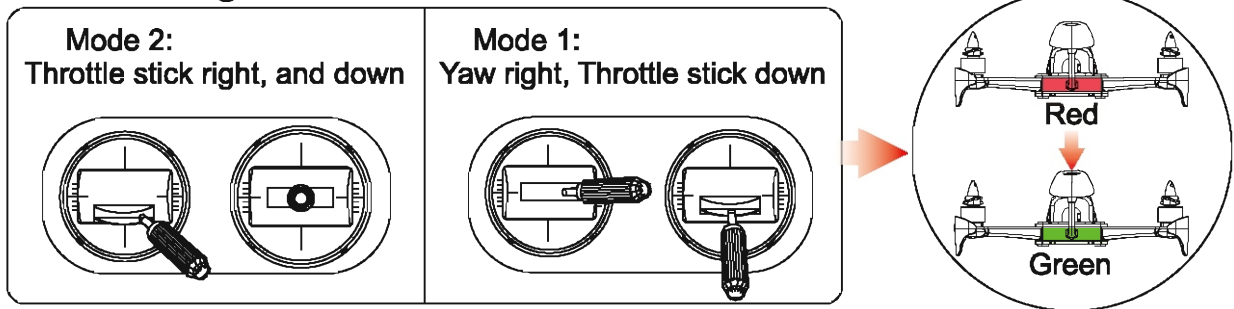

### ▪ Disarm Flight Controller:

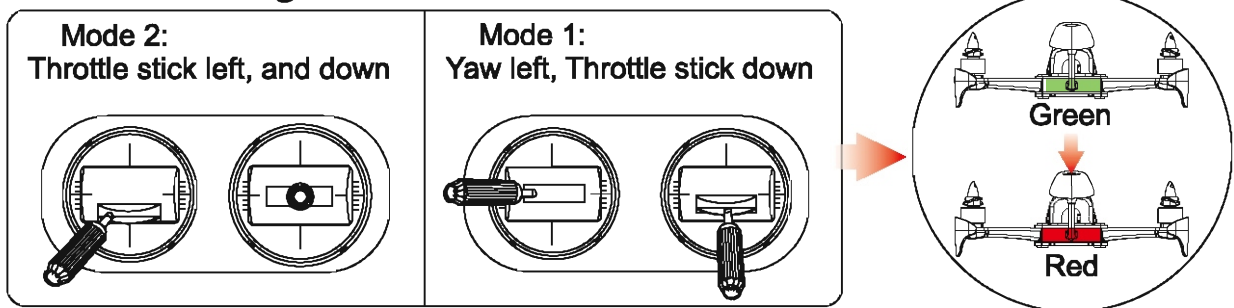

Note : The user can customize the state of LED.

## 7. OSD(On Screen Display)

### Enter OSD Menu

Mode 2:

Throttle stick middle(about or more ), roll left and up.

Mode 1:

Yaw left and up, Throttle stick middle(about or more).

Betaflight OSD, with the full ability to alter every setting directly via your transmitter. It is easy to use operating capability without the need of a PC, and just use the RC Tx stick movements, you can adjust All parameters, including PIDs, Expos, Loop time, etc. are available. **(But the 180 base has no OSD, and you must use PC to adjust parameters.)**

## 8. Firmware Upgrades

To upgrade the Flight-Controller firmware, use the betafight-configurator:

**(1) Remove all Props!**

**(2) Download and flash the firmware.**

The PC must supports the betafight configurator to choose the firmware (OMNIBUSF4SD).

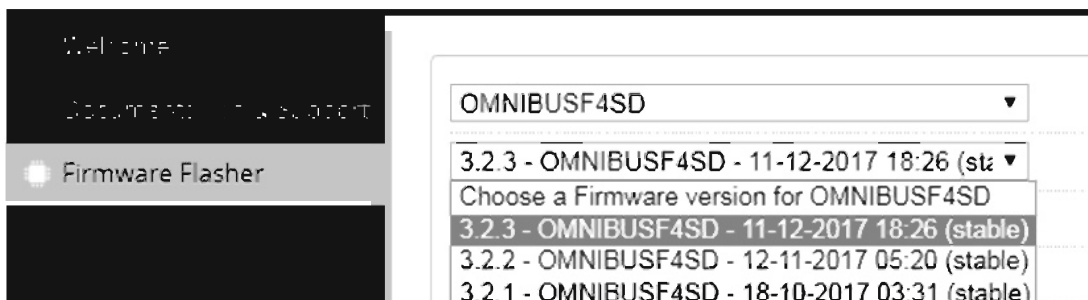

**(1)Firmware flasher**

----omnibusf4 sd

----choose the firmware

----load firmware(online)

**(2)Push the boot button, connect the aircraft to betafight configurator**

----flash firmware

Programming successful !

**Note:**

Base 180 please choose the SPRACING F3.

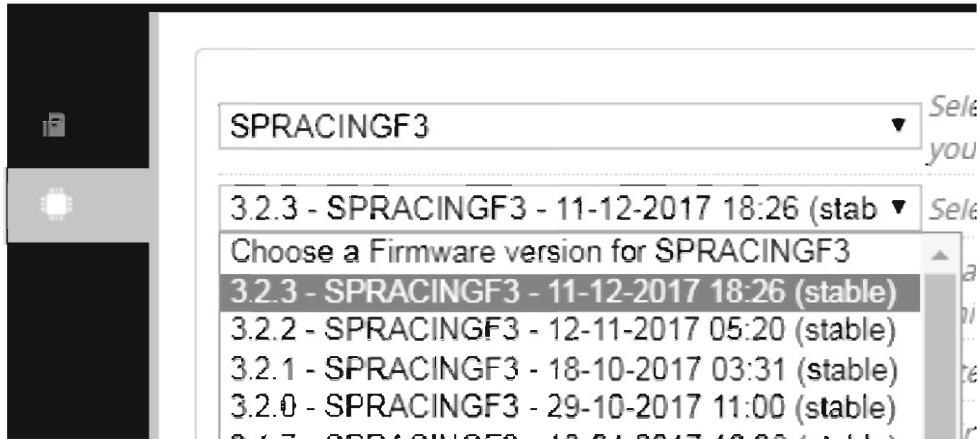

## 9. Charging

- (1) Please firstly connect the B3 charger to power, while the three power LEDs will turn from red to green , which indicating that the charger works in good order.
- (2) (Set 3s battery pack for example) Secondly , please connect the battery pack to 3s balance port , while the three power LEDs will all turn into red and charging begins. Please note once the charging of one cell is done , the corresponding power LED for it will turn green.
- (3) When the three power LEDs all turn green , the charger for 3S battery pack is finished.

## 10. Notes for flight

- (1) It is intended for pilots aged 14 or above with model hobby experience.
- (2) Only fly it in dry weather with low wind, please do not fly in rain, snow or heavy foggy conditions.
- (3) An open field lawfully permitted must be selected for flying in line with your mental conditions and flying skill.
- (4) Always keep a certain distance from the Race Drone and keep it from high-speed rotating parts, such as propellers or brushless motors.
- (5) Do not fly around high-voltage power lines, cellphone basestation or radio towers, as they are likely to interrupt your communication.
- (6) Always check local laws before flying, never fly an illegal flight.

