

For ages 14+

User Manual

(must read before use)

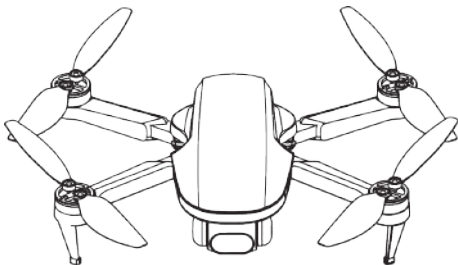

- (It is prohibited to take 10 kilometers on both sides of the airport runway centerline and 20 kilometers on each end of the runway) and civil aviation routes and routes. Stop using all kinds of models, drones.
- When using, it must be kept away from obstacles and crowds
- Pay attention to the temperature of the surrounding environment when using, avoid high and low temperature and humid environment
- When using, pay attention to the surrounding climate and environment, and cannot be used in windy days or thunderstorms.

product description

Propeller installation

Please make sure all propellers are installed in the correct orientation according to the diagram below. If the installation is wrong, the aircraft will not be able to fly normally.

(Fan blades have A/B distinction)

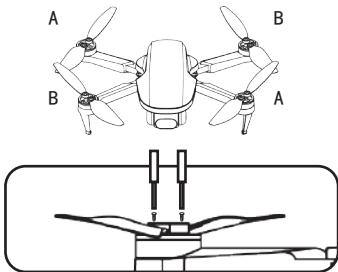

Battery Installation/Battery Removal

Install the battery: Insert the battery into the aircraft battery compartment as shown in the figure below (arrow 3). After the installation is complete, please check to ensure that the battery is installed in place.

Battery removal: Press the battery latch (arrow 1), and then remove the battery in the direction of (arrow 2).

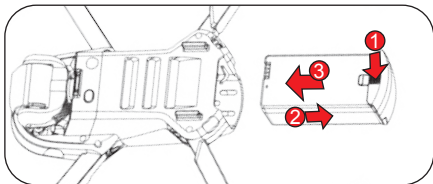

aircraft battery charging

Connect the battery to a 5V 1-2A charging adapter with a USB charging cable, and charge the battery after connecting. When the battery is charging, the battery indicator light is on for a long time, and the battery indicator light is off when the battery is fully charged, and the charging time is about 4 hours.

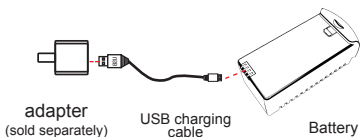

Please try to use an adapter with a charging current of 2A for charging, which can improve the charging speed.

Remote control charging

When charging, the charging indicator light is red, and the red light is off when fully charged

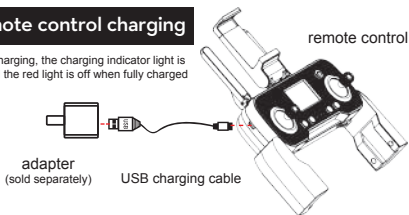

Kind tips:



- Please insert the plug in the correct way.
- It is recommended to use a 5V 1-2A adapter for charging.
- When charging the rechargeable battery, do not use it alone for children, it must be carried out under the supervision of an adult, and it must be kept away from flammable materials when charging. Do not place the battery in a high temperature, heated place (such as in a fire or near electric heating devices).
- Please do not short circuit or squeeze the battery to avoid explosion.
- The battery needs to be charged and stored after the flight. If it is not in use, it is recommended to charge the battery at least once every 3 months to prevent the battery from being over-discharged and permanently damaged.

Remote control function introduction

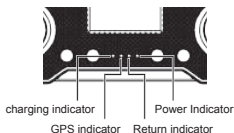
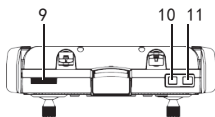
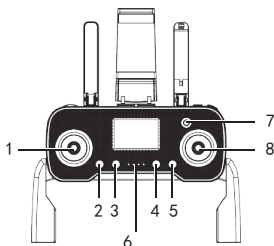

[1] Up/down/left/right rotation



[2] GPS switch



[3] Short press headless mode/long press one button to take off or land



[4] Short press the gyroscope/long press the geomagnetic calibration



[5] One-key return

[6] Indicator light



[7] Power switch

[8] Front and rear/left and right

[9] (Roller) Camera angle adjustment



[10] Short press to take pictures/long press to record



[11] Speed switch

takeoff steps

1. Both the remote control and the drone battery must be fully charged before takeoff.
2. The drone arms and fan blades need to be fully unfolded.
3. Turn on the drone switch first, and then turn on the remote control switch to perform frequency pairing
4. WiFi connection between drone and mobile phone (note: not bluetooth)
5. Install the mobile phone holder on the remote control, install the mobile phone on the mobile phone holder, and open the APP of the drone to operate.

Connect to APP (mobile phone needs to support 5G band WiFi signal)

After turning on the mobile device, scan the QR code on the APP manual and download the APP, turn on the WIFI function of the mobile device, select HF GPS5G_***** in the WIFI list to connect, exit the interface, and open the APP.



At this time, turn off the remote control. If you want the mobile phone to directly control the flight of the drone, you must turn off the power of the drone and turn it on again, and reconnect to the mobile APP.

For APP operation instructions, please refer to the APP manual.

Outdoor mode operation steps:

Turn on the drone - connect the mobile phone - remote control frequency - gyroscope correction - geomagnetic correction - GPS signal search star - unlock - take off

Indoor mode operation steps:

Turn on the drone - connect the mobile phone - connect the remote control to the frequency - gyroscope correction - turn off the GPS (the default is on) - unlock - take off

1. Aircraft pairing:

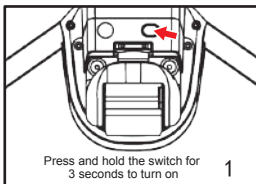

Press and hold the switch for 3 seconds to turn on

1

1. First, press and hold the power button of the aircraft for 3 seconds to turn it on, and then place it on the ground horizontally. At this time, the front and rear LED lights of the aircraft flash for self-checking.

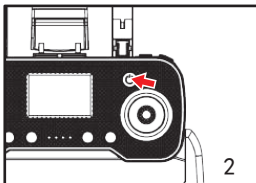

2. At the same time, when the remote control power is turned on, the code is matched, and the remote control will make a beep. At this time, the status of the front LED light of the aircraft turns into a long light, and the rear LED light flashes, indicating that the code is successfully matched.

 The frequency pairing is successful, the front light is always on, and the rear light is flashing. If the front light and rear light are flashing at the same time, and the indicator light of the remote control is also flashing, it proves that the frequency is not successful or the battery of the drone is low, and the drone needs to be restarted to re-wire.

2. Gyro calibration function:

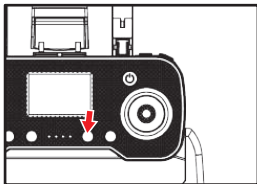

After the aircraft is successfully paired, place the aircraft on a flat ground, short press the gyro calibration button, the remote control beeps, and the front and rear lights flash quickly, indicating that the calibration is successful. At this time, you can search for GPS signals, and after the light is on, you can control the aircraft to unlock and take off. If you don't need GPS signals, you can take off directly.

3. Geomagnetic correction function:

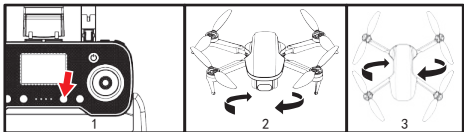

When flying in outdoor GPS state, geomagnetic correction must be performed on the first flight. When the aircraft is successfully paired, press and hold the geomagnetic calibration button for 2 seconds, the remote control will make a beep, and the aircraft's LED lights will flash rapidly at this time, and the geomagnetic calibration can be started.

1. First pick up the aircraft 1 meter above the ground, level it with the ground, and turn it clockwise three times. At this time, the remote controller emits a short beep, the rear LED light is on, the front LED light flashes, and the horizontal geomagnetic correction is completed. Then put the aircraft upright, perpendicular to the ground, and turn it clockwise three times. At this time, the remote controller emits a long beep, the front LED light is on, and the rear LED light flashes, indicating that the vertical magnetic calibration is successful. At this time, the search GPS signal light is always on, and you can unlock and take off. If you do not need GPS fixed-point flight, you can fly directly.



The geomagnetic correction must be completed in both the horizontal and vertical directions to be successful. When the geomagnetic correction fails, the takeoff cannot be unlocked, and the geomagnetic must be re-calibrated. After the geomagnetism is calibrated at the same location, it is not necessary to calibrate every flight.



Do not calibrate in areas with strong magnetic fields, such as magnetic mines, parking lots, large metals in construction areas with underground steel bars, etc.

5. Search GPS signal:

After the frequency is set, the LED light enters a fast flashing state. When the LED light stops flashing and turns into a long light, or when the remote control emits a beep, it indicates that the GPS signal has been searched and can be unlocked and taken off.



Please ensure that the take-off environment is open and the satellite signal is more than 6 satellites searched before take-off. 
The first star search time is about 1 minute to 1 minute and 30 seconds.

6. Aircraft unlock:

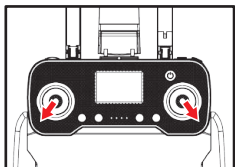

At this time, the throttle stick and the direction stick are pushed to the lower left corner and the lower right corner at the same time to complete the unlocking. After the motor is started, you can fly.

⚠ Fully unfold the fan blades before unlocking.

Features

One-key takeoff/landing

- After the aircraft is unlocked, press and hold the button for 2 seconds, the aircraft will automatically take off and hover at a height of about 1.5 meters.
- When the aircraft is in flight, press and hold the button for 2 seconds, the aircraft will automatically land on the ground.

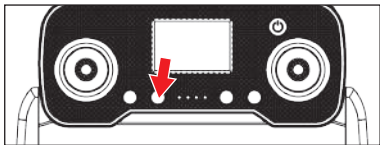

headless mode

Press the headless mode button, the remote control emits a "beep" sound, when the aircraft is unlocked, the direction the nose points to is the front of the flight. During the flight, turn the aircraft in the direction, and the aircraft is still unlocked when the aircraft is in front of the flight. , the direction the nose is pointing.

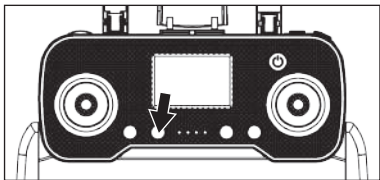

Return home (optical flow mode does not have this function)

The aircraft has a return-to-home function. If the home point is successfully recorded before takeoff, the aircraft will automatically return to the home point and land when the communication signal between the remote control and the aircraft is lost or when the return button is pressed to prevent accidents. There are three different ways to return the aircraft,

They are:

1. One-key return
2. Lost contact and return
3. Low battery return

Notes for return flight:

- During the auto-return process, the aircraft cannot avoid obstacles.
- When the GPS signal is poor or the GPS does not work, you cannot return home.

Return point:

During takeoff or flight, when the GPS receives more than 6 stars for the first time, it will be recorded as the current position of the aircraft as the home point.

One key return

When the GPS signal is good (the number of satellites is greater than 6), you can start the aircraft to return to home by pressing the button below on the remote control. The process of returning to home is the same as that of returning to home after losing contact. The difference is that when the aircraft returns and lands, the user can use the joystick to control the aircraft to avoid obstacles. , through the return key to exit the return home, and the user can re-control the drone flight.

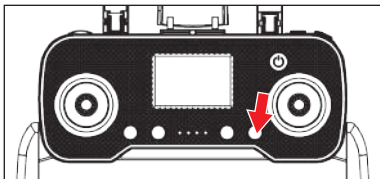

Lost contact and return

After the GPS signal is good (the number of GPS satellites is greater than 6), the compass is working normally, and the aircraft successfully records the home point, if the remote control signal is interrupted, the drone will automatically return to the place where there is a signal, and then automatically connect to the remote control.

low battery return

When the aircraft is low-voltage, the indicator light will flash slowly, and the remote controller will emit a continuous alarm sound of "dididi". At this time, the aircraft will automatically return to the 20 meters near the take-off point. (When the aircraft returns to the vicinity of the take-off point after low power, the altitude and distance of the aircraft will be limited to within 20 meters)



Reminder: The aircraft is in a low power return-to-home state, and the remote control cannot cancel the return-to-home.

Photo/Video

Short press the camera and video button on the remote control, and the mobile APP will display the progress bar of the photo archive.

Press and hold the camera and video button on the remote control for 2 seconds, and the mobile APP will display the recording time and save it.

Short press to take photo/long press for 2 seconds to record

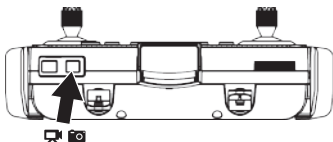

Camera angle control

Through the remote control wheel button, you can adjust the shooting angle of the gimbal camera (as shown in the figure)

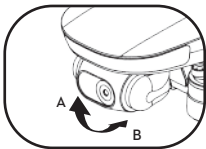
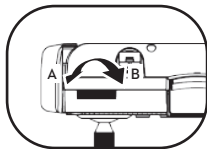

Flight control method:

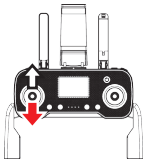
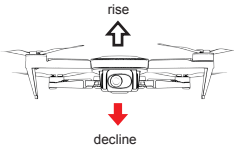
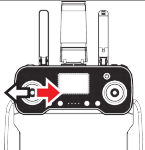
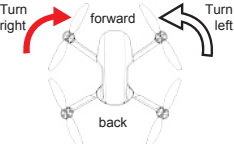
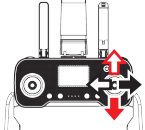
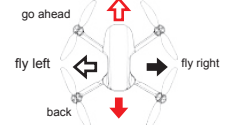
remote control	aircraft
	 <p>rise</p> <p>decline</p>
	 <p>Turn right</p> <p>Turn left</p> <p>forward</p> <p>back</p>
	 <p>go ahead</p> <p>fly left</p> <p>fly right</p> <p>back</p>

Mode switch

1. Indoor mode. After the aircraft is successfully paired, the aircraft defaults to GPS mode indoors. To take off indoors, first press the GPS switch on the remote control to switch to indoor mode, which can unlock and take off.

Note: When the aircraft is in the following environment, the optical flow positioning and hovering effect of the lower lens is not good, which will make it difficult for the aircraft to fly smoothly, resulting in the phenomenon of body shake.



on the water



dim light



Great height difference



smooth reflective floor



two-tone stripes

2. [GPS Mode] After the aircraft is successfully paired, in the outdoor environment, the aircraft will automatically enter the satellite search mode. When searching for satellites, place the aircraft in an open area, and there should be no obstructions such as tall buildings or wires around, and wait for the number of satellites to reach 6. Positioning is completed left and right, the remote control will beep to prompt to enter the GPS mode, the arm light is always on, and it can be unlocked and taken off.

Common troubleshooting

serial number	question	Solution
1	After taking off indoors, the aircraft cannot hover and floats around.	The take-off height is too low, the ground is too smooth, and the environment is too dark, which will cause the optical flow to fail.
2	After taking off outdoors, the aircraft kept blinking and could not hover, and floated around. The remote control keeps switching between modes 1 and 2.	The GPS positioning is not good, and the interference is too large. Please take it to an open area, no shelter, no wires, etc., and recalibrate the geomagnetism.
3	The aircraft vibrates violently	The fan blade is deformed or the motor is damaged, the fan blade and motor need to be replaced
4	The motor of the aircraft can run, but it cannot fly, and the lights flash quickly and slowly	Check whether the fan blade AB is installed incorrectly, or the geomagnetic correction fails



MADE IN CHINA