

# UPair

A Quick Start Guide for CHASE

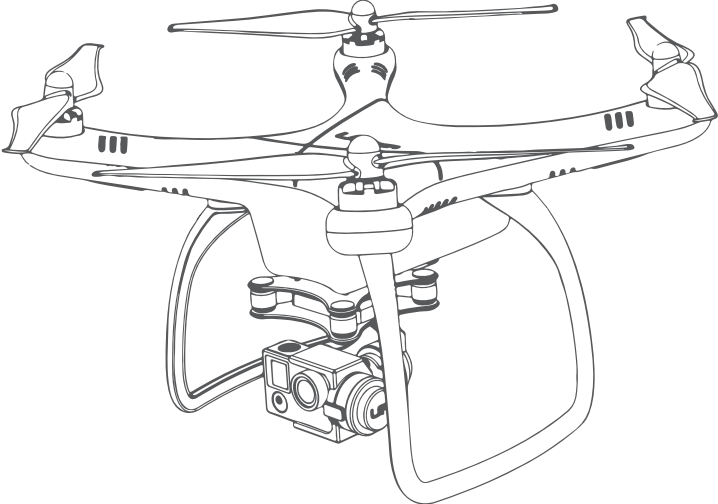

# Contents

Contents .....	1
Instructions Before Use .....	2
A General Introduction .....	3
Aircraft .....	3
Aircraft Parameter .....	3
Indicator Descriptions .....	4
Remote Controller .....	4
Operation of the Remote Controller(Mode2) .....	5
Operation of the Remote Controller(Mode1) .....	6
The Parameter of the Remote Controller and Real-time FPV .....	7
FPV Screen .....	7
OSD Interface .....	7
Instructions for Use .....	7
Charging the Remote Controller .....	8
Gimbal .....	9
Gimbal Parameter .....	9
Attaching the Camera to the Gimbal .....	9
Camera .....	10
Camera Parameter .....	10
LED Status .....	10
Menu Description .....	11
Camera Functions .....	12
Intelligent Battery .....	13
The parameter of the Intelligent Battery .....	13
Functions of the Intelligent Battery .....	13
Charging the Intelligent Battery .....	13
Battery Level Indicator Status .....	14
Cautions Regarding the Use of the Intelligent Battery .....	14
Before a Flight .....	15
Installing the Propellers .....	15
Switching on the Remote Controller and FPV Monitor .....	15
Installing and Powering on the Intelligent Battery .....	16
Starting the Motors(Mode2/Mode1) .....	16
About the Flight .....	17
Stopping the Motors(Mode2/Mode1) .....	17
Cautions Before/During a Flight .....	18
Failsafe Function .....	18
Auto Return Triggered by Low Voltage .....	18
Failsafe Auto Return .....	18
After-sale Service .....	18

## Instructions Before Use

Before using this product, please thoroughly and carefully read the entire manual and operate Chase in accordance with the following instructions:

1. Before each flight, please make sure you have fully understood and will obey local laws and regulations.
2. Please check if all the accessories and/or components are ready for use and in good condition, otherwise, please do not operate Chase.
3. Please install the propellers in accordance with the instructions and make sure they are correctly and firmly installed, so as to prevent propellers from falling off the aircraft during the flight, which may cause unexpected damage.
4. Before each flight, please make sure the remote controller, the camera and the aircraft are fully powered.
5. It is advised to operate Chase in open areas, away from buildings, high-voltage power lines, in order to avoid interference between the remote controller and communication base stations, Wi-Fi etc.
6. Before each flight, please power on the remote controller before switching on the aircraft; After the landing, please power off the aircraft before switching off the remote controller.
7. Before each flight, please make sure the aircraft is kept clear of any objects and/or persons within a radius of 10m, and keep the aircraft away from obstacles such as crowds, high-voltage power lines, trees and water surface etc.
8. During the entire process of descending, please keep the aircraft stable ;When it closes to the ground, it is advised to make it loiter for a few seconds before the ground is confirmed flat and smooth, then make it slowly descend to the ground. The locking process may take ten or more seconds , please be patient.
9. Please don't fly the aircraft under harsh weather conditions like strong wind, heavy snow or rain or thick fog etc.
10. Please do not operate the aircraft in restricted areas or no-fly zones under relevant laws and/or regulations, airport for example.
11. Please do not operate the aircraft when you are in poor mental state (such as intoxication ).
12. Please keep the aircraft, accessories and components out of children's reach; In case any accessories and /or components are swallowed by a child, he or she should be immediately taken to a doctor for treatment.
13. If the aircraft is to be left idle for a long period, please take out the battery , place the aircraft in an environment free from dampness, moisture, mould and exposure to strong sunlight.
14. UPair shall assume no responsibility and/or liability for any consequences resulting from unauthorized mounting/dismounting, assembly/disassembly and/or modification of Chase.

Much thanks for your purchasing UPair product. Please use the product in strict compliance with this manual.

This product and the intellectual property right of the manual belong to UPair, without written permission from UPair, no organization or individual is permitted to reprint, copy or distribute any contents of this manual in any forms.

If you have any questions or problems when using this product, please contact UPair authorized distributors or UPair Customer Service.

# A General Introduction

## Aircraft

Developed by UPair, Chase is a quadcopter equipped with a gimbal, a camera and a built-in flight control system; It is capable of auto return, ascending/descending, pitching, shooting, video recording with the unique function of failsafe auto return or auto return triggered by low battery voltage.

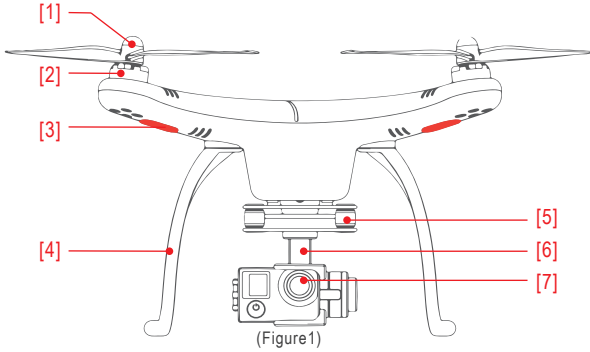

- [1] Propeller
- [2] Motor
- [3] Red LED Flight Indicator(nose)
- [4] Landing Gear
- [5] Anti-vibration Device
- [6] Gimbal
- [7] Camera

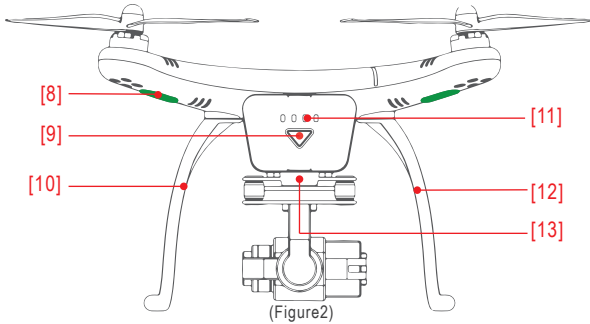

- [8] Green LED Flight Indicator(tail)
- [9] Battery Power Button
- [10] Telecontrol Antenna(built-in)
- [11] Battery Level Indicator
- [12] FPV Antenna(built-in)
- [13] Linking Button

## Aircraft Parameter

Total Weight	1350g	Max Vertical Speed	4.5m/s
Height (with landing gear )	220mm	Max Tilt Angle	45°
Wheelbase	355mm	Max Pan Speed	14m/s
Propeller	9450	Hovering Accuracy (during a safe flight)	Vertical: 1m Horizontal: 1.6m
Motor	2212		
Loitering Duration	Full-load (1350g): 19minutes; Aircraft alone(1085g): 25minutes		

## Indicator Descriptions

The LED flight indicators on the aircraft arm indicate the directions of the aircraft. When the aircraft is powered on, the LED indicators light up. The red indicator represents the nose while the green indicator represents the tail.

## Remote Controller

The remote controller is integrated with a 2.4G telecontrol transmitter, a seven-inch screen and a 5.8G FPV receiver, the link between the remote controller and the receiver has been established. The remote controller is set to Mode 2 by default.

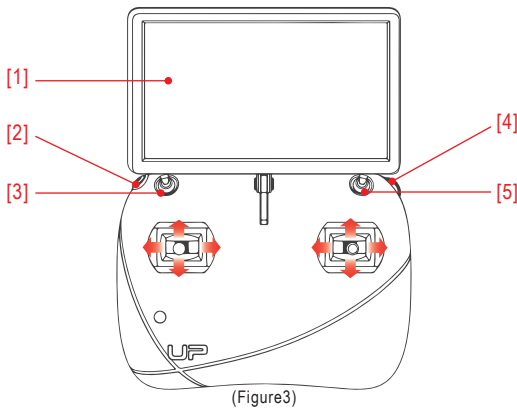



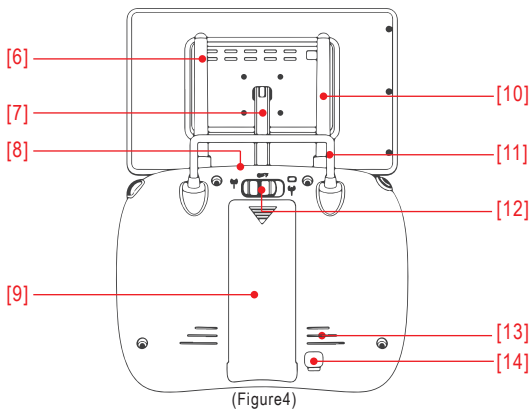







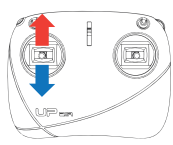
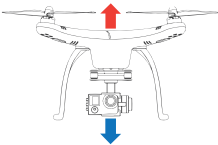
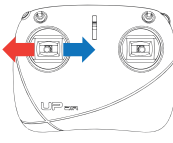
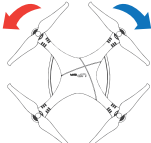
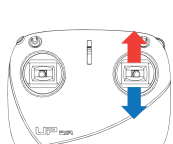
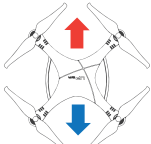
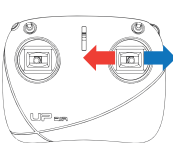
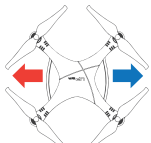



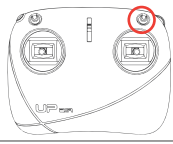

- [1]FPV Monitor
- [2]Shooting(upward)  
Video recording(downward)
- [3]Shutdown Mode(forward)  
Home Point(backward)
- [4]Gimbal Pitching
- [5]Althold(forward)  
Poshold(mid-point)  
Easy Mode(backward)

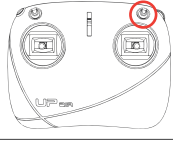



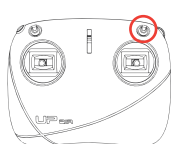





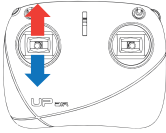
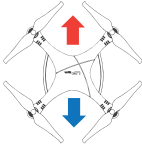
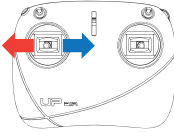
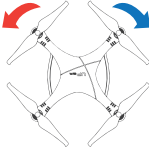
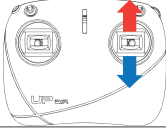
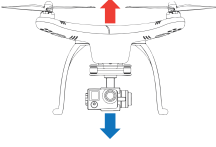
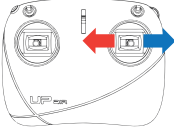
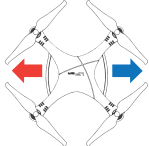

- [6]2.4G Telecontrol Antenna
- [7] FPV Monitor Holder
- [8]Monitor Power /FPV Signal Interface
- [9]Battery Cover
- [10] 5.8G FPV Antenna
- [11]Carrying Handle
- [12]Remote Controller On(left)  
Remote Controller Off (mid-point)  
FPV and Remote Controller On(right)
- [13]Ventilation Hole
- [14]FPV FM Button

[8] is a specially designed interface for Upair FPV, into which no other device is allowed to be inserted

## Operation of the Remote Controller(Mode2)

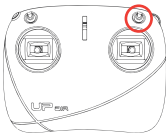
Remote Controller	Aircraft	Althold/Poshold/Easy Mode
		<p>Push up the joystick on the left(illustrated as the red arrow) to make the aircraft ascend.</p> <p>Pull down the joystick on the left(illustrated as the blue arrow) to make the aircraft descend.</p>
		<p>Push the joystick leftward(illustrated as the red arrow) to make the aircraft rotate counter clock-wise.</p> <p>Push the joystick rightward(illustrated as the blue arrow) to make the aircraft rotate clock-wise.</p> <p>The aircraft has a maximum rotating angular velocity of 200°/s.</p>
		<p>Push up the joystick on the right (illustrated as the red arrow) to make the aircraft tilt and fly forward.</p> <p>Pull down the joystick on the right(illustrated as the blue arrow) to make the aircraft tilt and fly backward.</p>
		<p>Push the joystick leftward (illustrated as the red arrow) to make the aircraft tilt and fly leftward.</p> <p>Push the joystick rightward (illustrated as the blue arrow) to make the aircraft tilt and fly rightward.</p> <p>The aircraft has a maximum tilt angle of 30°.</p>
Remote Controller	Switch Positions	Flight Mode
	<p>Front </p> <p>Back </p>	<p>Home Point Mode</p> <p>Pull the switch backward(as illustrated in the left figures) to make the aircraft enter Home Point Mode, then it will fly back to the take-off point.</p>
	<p>Front </p> <p>Mid </p> <p>Back </p>	<p>Althold Mode</p> <p>Push the switch forward(as illustrated in the left figures) to make the aircraft enter Althold Mode, in which the aircraft will fly in the current altitude.</p>
	<p>Front </p> <p>Mid </p> <p>Back </p>	<p>Poshold Mode</p> <p>Set the switch to the mid-point(as illustrated in the left figures) to make the aircraft enter Poshold Mode, in which the aircraft will maintain its current position.</p>
	<p>Front </p> <p>Mid </p> <p>Back </p>	<p>Easy Mode</p> <p>Pull the switch backward(as illustrated in the left figures) to make the aircraft enter Easy Mode, in which the aircraft is made to perform pitching, ascending/descending, rotating, tilting etc by the corresponding buttons of the remote controller, regardless of where the nose of the aircraft is facing, so the user can operate it freely.</p>

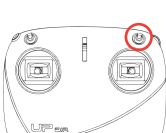
## Operation of the Remote Controller(Mode1)

Remote Controller	Aircraft	Althold/Poshold/Easy Mode
		<p>Push up the joystick on the left(illustrated as the red arrow)to make the aircraft fly forward.</p> <p>Pull down the joystick on the left(illustrated as the blue arrow) to make the aircraft fly backward.</p>
		<p>Push the joystick leftward(illustrated as the red arrow) to make the aircraft rotate counter clock-wise.</p> <p>Push the joystick rightward(illustrated as the blue arrow) to make the aircraft rotate clock-wise.</p> <p>The aircraft has a maximum rotating angular velocity of 200°/s.</p>
		<p>Push up the joystick on the right(illustrated as the red arrow) to make the aircraft ascend.</p> <p>Pull down the joystick on the right(illustrated as the blue arrow) to make the aircraft descend.</p>
		<p>Push the joystick leftward (illustrated as the red arrow) to make the aircraft tilt and fly leftward.</p> <p>Push the joystick rightward (illustrated as the blue arrow) to make the aircraft tilt and fly rightward.</p> <p>The aircraft has a maximum tilt angle of 30°.</p>
Remote Controller	Switch Positions	Flight Mode
	<p>Front <input type="checkbox"/> L</p> <p>Back <input type="checkbox"/> </p>	<p>Home Point Mode</p> <p>Pull the switch backward(as illustrated in the left figures) to make the aircraft enter Home Point Mode, then it will fly back to the take-off point.</p>
	<p>Front <input type="checkbox"/> L</p> <p>Mid <input type="checkbox"/> </p> <p>Back <input type="checkbox"/> </p>	<p>Althold Mode</p> <p>Push the switch forward(as illustrated in the left figures) to make the aircraft enter Althold Mode, in which the aircraft will fly in the current altitude.</p>
	<p>Front <input type="checkbox"/> L</p> <p>Mid <input type="checkbox"/> </p> <p>Back <input type="checkbox"/> </p>	<p>Poshold Mode</p> <p>Set the switch to the mid-point(as illustrated in the left figures) to make the aircraft enter Poshold Mode, in which the aircraft will maintain its current position.</p>
	<p>Front <input type="checkbox"/> L</p> <p>Mid <input type="checkbox"/> </p> <p>Back <input type="checkbox"/> </p>	<p>Easy Mode</p> <p>Pull the switch backward(as illustrated in the left figures) to make the aircraft enter Easy Mode, in which the aircraft is made to perform pitching, ascending/descending, rotating, tilting etc by the corresponding buttons of the remote controller, regardless of where the nose of the aircraft is facing, so the user can operate it freely.</p>

## The Parameter of the Remote Controller and Real-time FPV

Total Weight	826g	Battery Voltage	11.1V
Number of Channels	10	Battery Capacity	2200mAh
Telecontrol Antenna Frequency	2.4GHz	Communication Range of RC	About 1km
FPV Frequency	5.8GHz	Communication Range of FPV	About 1km

Linking Procedures:When the remote controller and the aircraft are powered on, hold down the “FPV FM”button on the back of the remote controller ,the indicator blinks ,indicating the auto linking is started; When the indicator changes to solid green,then the linking is successfully established. When two or more quadcopters are operated at the same time, if the frequency points are in conflict, it is advised to reestablish the linking, please press the “Linking” button(refer to Figure2) of the aircraft to change to another channel,then hold down the “FPV FM”button on the back of the remote controller, when the current images on the FPV screen are confirmed to be streamed down from your aircraft, it indicates the linking is successfully established.

## FPV Screen

Chase Remote Controller is equipped with a built-in 5.8GHz FPV receiver, which works correspondingly with a built-in 5.8GHz transmitter of the aircraft, so the real-time images can be streamed from the camera to the FPV screen

## OSD Interface

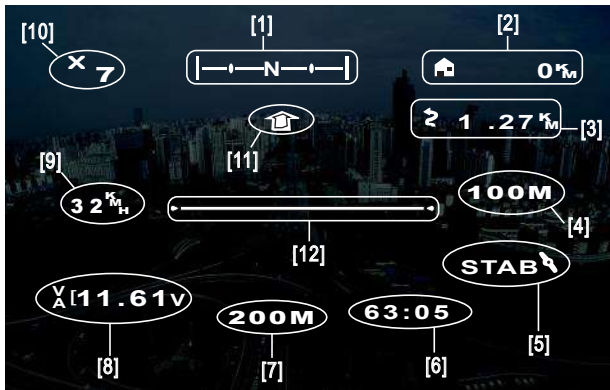

(Figure5)

- [1]Nose Direction
- [2]Home Distance
- [3]Total Cruising Range
- [4]Flying Altitude
- [5]Flight Mode
- [6]Time
- [7]Altitude
- [8]Voltage
- [9]Flight Speed
- [10]Number of Satellites
- [11]Home Direction
- [12]Aircraft Attitude Line

Note: When the aircraft, remote controller and FPV are switched on, the self-examining process of the flying altitude is displayed on OSD interface, “the flying altitude” rises, then drops to a constant figure; After this, it is advised to unlock the aircraft (refer to page 16 and page 17) to ensure a stable flight.

## Instructions for Use

Shooting :When the “Shooting” button is pressed , a small icon (shown in Figure6) appears on the FPV screen, indicating the camera has entered the shooting mode.

Video Recording: When the “Video Recording” button is pressed , a small icon (shown in Figure7) appears on the FPV screen, indicating the camera has entered the video recording mode.





(Figure6)



(Figure7)

## Charging the Remote Controller

1. Slide down the rear cover of the RC battery compartment(Figure10), pull the battery out.
2. Charge the RC battery(Figure8) by connecting the RC battery with the charger(Figure9).
3. When the charger indicators turn red ,it indicates charging is in process ;when the charger indicators turn green, it indicates the battery has been fully charged. If the charger indicators blink red and green, it indicates the charger has been powered, but has not been correctly connected with the battery.
4. Disconnect the RC battery with the charger when it is fully charged, then put the battery into the battery compartment.

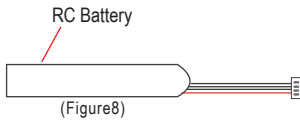

(Figure8)

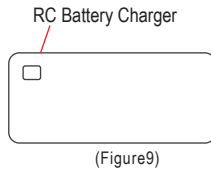

(Figure9)

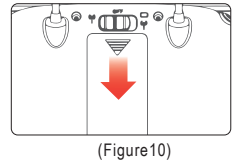

(Figure10)

## Gimbal

Powered by a flight intelligent battery , the Chase two-axis stabilization gimbal is designed for carrying a camera; Gimbal angle can be adjusted by the corresponding button of the remote controller during a flight.

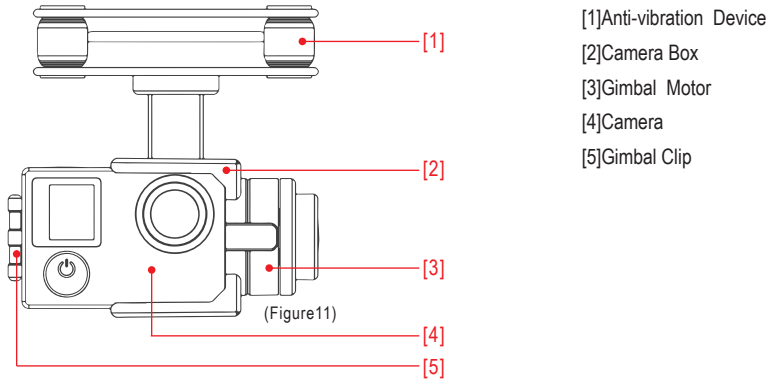

## Gimbal Parameter

Angle Control Precision	$\pm 0.2^{\circ}$	Operating Voltage	11.1V
Rotational Range	Pitching $-30^{\circ} \sim 90^{\circ}$	Maximum Control Speed	Pitching $15^{\circ}/s$

## Attaching the Camera to the Gimbal

Separate the clip ,push the camera into the camera box(Figure12) , then release the clip to make sure the camera is securely fastened.

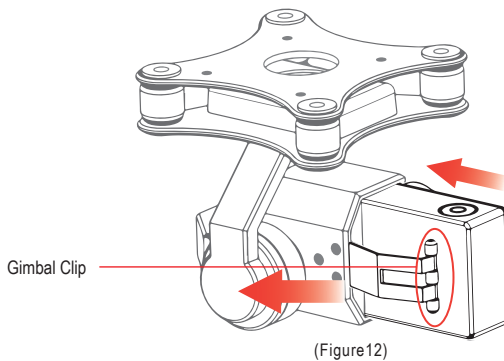

## Camera

Powered by the flight intelligent battery, Chase camera proper has the function of shooting and video recording, which can also be done by the corresponding buttons of the remote controller. Chase Camera supports single shooting, continuous shooting, time-lapse shooting, and HD 1080P video.

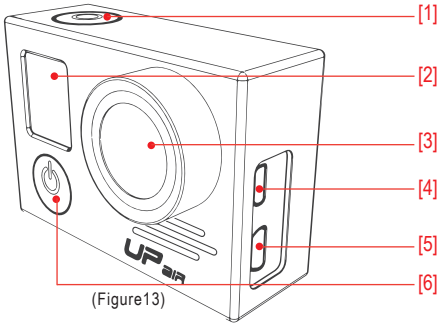

- [1]OK Button
- [2]LED Screen
- [3]Camera Lens
- [4]HDMI Output

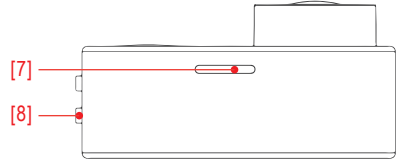

- [5]USB/AV Port
- [6]Power/Mode Button
- [7]TF Card Slot
- [8]Up/Down Button

## Camera Parameter





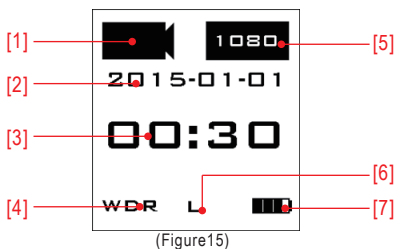





Weight	70g	Camera Lens	SONY Lens (2K/4K)
Dimension	59x41x21mm	Video/Photo Format	*.MOV / *.JPG
Battery Capacity	1600mAH	Working Voltage	5V
Supported Maximum TF Card	64G	Functions	Shooting, Video recording, Continuous shooting, Time-lapse shooting
Charging Time	2~3 h		









## LED Status



- [1]Current Mode : Video Recording/Shooting
- [2]Date
- [3]Counter
- [4]WDR Status
- [5]Resolution
- [6]FOV Level
- [7]Battery Level

## Menu Description

	<p>Video resolution: Adjustable: 4K@24FPS、2.5K@30FPS、1080P@60FPS、720P@120FPS; 2K 1080P@30FPS、720P@60FPS.</p>
	<p>Time-lapse video: to start/stop time-lapse video at 0.5 or 3 second intervals.</p>
	<p>Cycle recording: If cycle recording mode is selected, the video will be cut into 5-minute segments. The earliest files will be covered when the TF card is full.</p>
	<p>USB Power Up Auto-record: If this function is on, it will automatically start recording when connected to external power source via USB.(This mode is advised to be used in aerial photography.)</p>
	<p>WDR (Wide Dynamic Range): WDR function is suggested to be used in cloudy/dark environment. It might cause overexposure on sunny days.(This mode is not suggested to be used on sunny days.)</p>
	<p>Photo resolution: 12M / 8M / 5M (12M is recommended.)</p>
	<p>Burst photo: capture 11 photos within 1 second.</p>
	<p>Continuous photo: This option allows you to capture photos continuously every 3/10/30 seconds. Note: Continuous photo mode has more priority than burst photo mode.</p>
	<p>ISO adjustment: AUTO/100/400/1600.ISO of photos can be adjusted. At night, the lower ISO you select, the better image effect can be achieved.(Note: please keep the camera stable when taking photos.)</p>
	<p>Sharpness adjustment: 3 options, namely, High, Medium and Low. Low sharpness is suggested at night.(Under recording mode, Medium level is suggested; under photographing mode, Medium level is suggested for close-shot or in dark environment and High level is suggested for long-shot.)</p>
	<p>Color adjustment: 2 options, namely, standard and vibrant.(If you want post-production, standard option is suggested.)</p>

 <p>STAMPING</p>	<p>Time Stamping: This option allows you to stamp the time on the photos or videos.</p>
 <p>TV-MODE</p>	<p>TV output format: PAL / NTSC.</p>
 <p>WIFI</p>	<p>Wi-Fi Output: When your mobile device(such as smart phone/tablet) has been connected to Wi-Fi , you can use it to view photo(s)/video(s) or make your mobile device capture photos or record videos (Note: A long distance between WIFI and camera might cause image loss.)</p>
 <p>USB</p> <p>AUTO POWER OFF</p>	<p>USB Auto power-off: The power will be automatically turned off in 30 seconds after the USB power supply is cut. (This function is suggested to be used in aerial photography.)</p>
 <p>ANGLE</p>	<p>Angle adjustment: 3 options- Large / Medium / Small. A small angle can reduce image distortion. (A large angle is suggested as a smaller angle might reduce image quality.)</p>
 <p>FORMAT</p>	<p>TF card formatting: When the camera is powered on, if the format of TF card is incompatible with the system, you will see a tip "please format card" and please use this function then.</p>
 <p>DEFAULT</p>	<p>Factory default settings: This function is designed for factory default. (Note: if the camera does not work normally, please restore all factory default settings and then restart.)</p>
 <p>V1.0</p> <p>VERSION</p>	<p>System version: Enter to see the system version of the camera.</p>

## Camera Functions

Name	Function	Description
Power/Mode Button	Power on/off, Mode Switching	Switch on the camera by pressing on the button; Hold the button down for 3 s to switch the camera off. Switch between Photo Mode and Video Mode
Ok Button	Start/Stop Recording	
Up/Down Button	Up/Down	Enter menu setting/move upward Enter menu setting/move downward

## Intelligent Battery

Chase is powered by an UPair approved intelligent lithium battery which has a full capacity of 5400mAh and a voltage of 11.1V; It must be charged with an UPair approved charger.

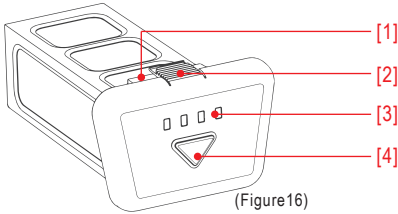

- [1]Charging Interface
- [2]Battery Box Clip
- [3]Battery Level Indicator
- [4]Power Switch

## Intelligent Battery Parameter

Battery Type	Lithium Battery	Charging Time	1~1.5h
Capacity	5400mAh	Environment Temperature for Charging	0°C ~ 40°C
Voltage	11.1V	Environment Temperature for Discharging	-20°C ~ 50°C

## Functions of the Intelligent Battery

Checking Battery Level: short press the “power switch” button when the battery is off.

Powering On the Intelligent Battery: when the battery is off, short press the “power switch” button, then hold down the button for at least 2s to power on the battery.

Powering Off the Intelligent Battery: when the battery is on, short press the “power switch” button, then hold down the button for at least 2s to power off the battery.

## Charging the Intelligent Battery

Please connect the charger plug (Figure18) to the charging interface(Figure 17) of the battery, when the battery level indicators blink green in sequence from left to right, it indicates charging is in process; when the battery level indicators stop blinking and go out, it indicates the battery has been fully charged.

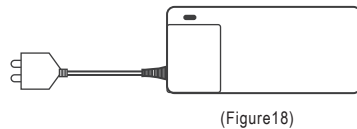
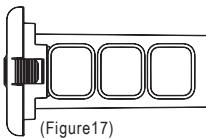

## Battery Level Indicator Status

Battery Level	Battery Level Indicator Status
100%	● ● ● ●
75%	● ● ● ○
50%	● ● ○ ○
25%	● ○ ○ ○

### Cautions Regarding the Use of the Intelligent Battery:

- Please immediately charge the intelligent battery and the remote controller after unpacking, always use Upair approved charger .
- When the current battery has been charged and discharged over 300 times, please replace it with a new one; If the battery is to be left idle for a long period, please make sure the battery capacity is below 50% when the storage begins.
- It is advised to thoroughly charge and discharge the battery once when it has been charged and discharged 20 times or so.
- Please use or store the battery in a fireproof location, otherwise it might result in battery overheat , fire, explosion, or cause other damage.
- In case electrolytic solution spurts into your eyes, please immediately wash your eyes and go to see a doctor.
- Never dispose of a battery irresponsibly, please thoroughly discharge the battery and make it insulated before throwing it into a special recycle bin.

# Before a Flight

## Installing the Propellers

1. Match the black-nut propeller with the motor with a hole in the center, then tighten the propeller by screwing it down counter clock-wise.(Figure19)
2. Match the grey-nut propeller with the motor without a hole in the center, then tighten the propeller by screwing it down clock-wise.(Figure20)

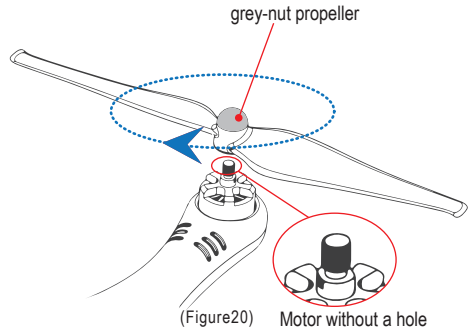
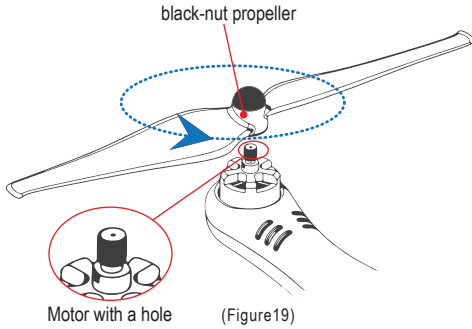

## Switching on the Remote Controller and FPV Monitor

On the back of the remote controller, there is a switch set at the mid-point by default, you can switch on the remote controller and FPV monitor by pushing the switch rightward.(Figure21)

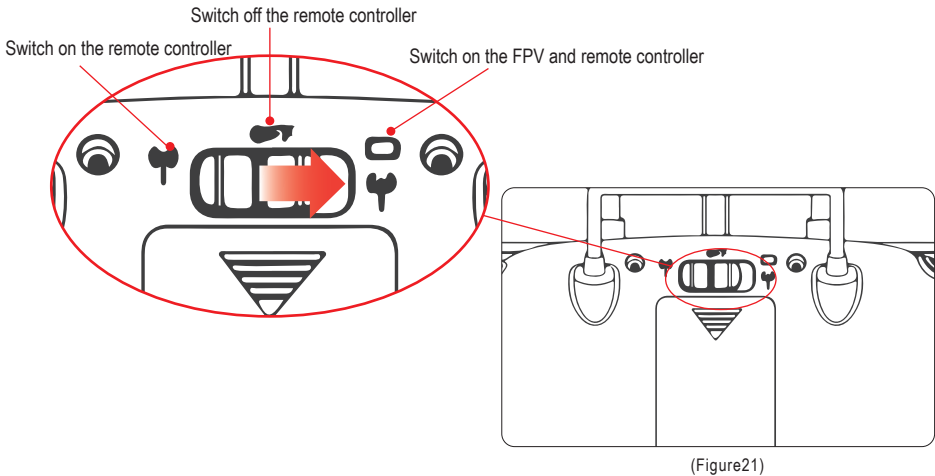



## Installing and Powering on the Intelligent Battery

1. Push the battery into the battery compartment(Figure22) until you hear a sound “click” , make sure the battery is tightly and correctly placed in the battery compartment.
2. When the battery is off , short press the power switch(Figure23), then hold the button down for at least 2s to power on the battery.

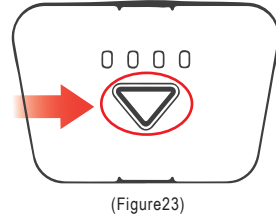
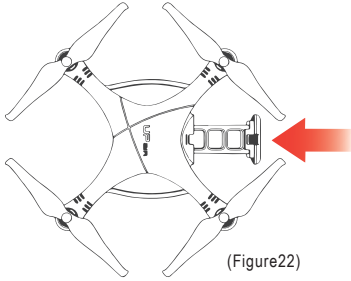

## Starting the Motors(Mode2/Mode1)

[Mode2] Starting the Motors : When the aircraft is powered on, please first conduct the self-examining of the flying altitude(refer to page 7), then pull the left joystick down(Figure24) and push it rightward(Figure25) to execute the “unlock” command, then release the joystick; After all these have been done , the motors can be started.

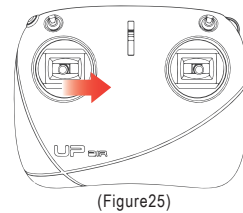
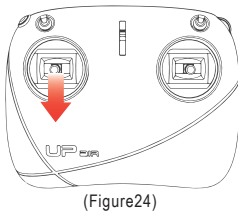

[Mode1] Starting the Motors : When the aircraft is powered on, please first conduct the self-examining of the flying altitude(refer to page 7), then pull the right joystick down(Figure 26) and push the left joystick rightward(Figure 27) to execute the “unlock” command, then release the joystick; After all these have been done, the motors can be started.

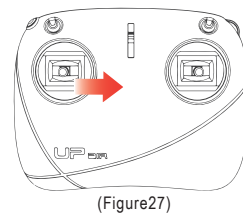
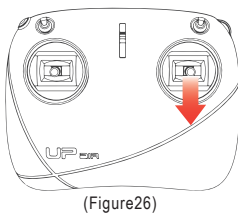

## About the Flight

Now you can start your flight, please strictly follow the instructions above (refer to page 5) to ensure a safe flight. In order to minimize misoperation, dead space has been made for the joystick of the throttle and direction, including throttle-up:10%, throttle-down:10% ; direction-left:5%, direction-right: 5%.

Mode2 for example

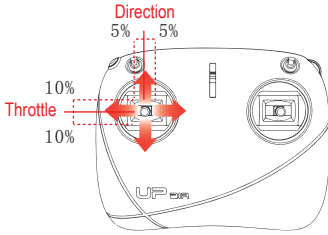

(Figure28)

Mode1 for example

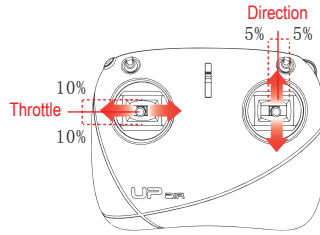

(Figure29)

## Stopping the Motors(Mode2/Mode1)

During the entire process of descending, please keep the aircraft stable ;When it closes to the ground, it is advised to make it loiter for a few seconds before the ground is confirmed flat and smooth, then make it slowly descend to the ground. The locking process may take ten or more seconds , please be patient.

[Mode2] Stopping the Motors: If you want to stop the working motors, please pull the left joystick down(Figure30) and push it leftward (Figure31)to execute the "lock" command , then the motors will immediately stop.

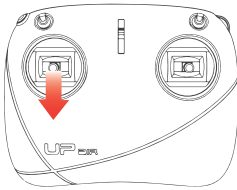

(Figure30)

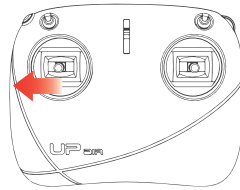

(Figure31)

[Mode1] Stopping the Motors: If you want to stop the working motors, please pull the right joystick down(Figure32) and push the left joystick leftward (Figure33)to execute the "lock" command , then the motors will immediately stop.

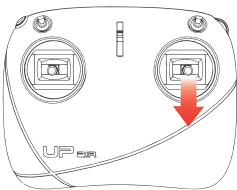

(Figure32)

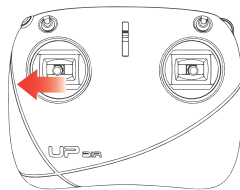

(Figure33)

## Cautions Before/During a Flight:

- Before each flight, please make sure the remote controller and the intelligent battery have sufficient power, and check if the propellers, the intelligent battery, the camera and the Micro-SD card have been securely and correctly installed.
- Before starting a flight, please switch on the remote controller before powering on the aircraft; After the landing, please power off the aircraft before switching off the remote controller.
- It is advised to operate the aircraft in open areas away from high-rise buildings, avoiding interference between the remote controller and communication base stations, Wi-Fi, high-voltage power lines etc.
- When operating the aircraft, please keep the aircraft away from obstacles, crowds, high-voltage power lines, trees and water surface etc.
- Please do not operate the aircraft under harsh weather conditions like strong wind, heavy snow or rain, thick fog etc.
- Please do not operate the aircraft in restricted areas or no-fly zones under relevant laws and/or regulations.

## Failsafe Function

### Auto Return Triggered by Low Voltage

During a flight, when the battery voltage is depleted to 10.6V or less, the "Auto Return" function will be triggered, which will make the aircraft fly back to the take-off point.

### Failsafe Auto Return

- During a flight, when the communication between the aircraft and the remote controller is interrupted, the aircraft loiters for 3s where the communication fails; During this brief moment of 3s, if the communication still can not be reestablished, the aircraft will return automatically.
- During the process of auto return, if the communication between the aircraft and the remote controller is successfully reestablished, the aircraft loiters where the communication is reestablished, waiting for commands from the remote controller, then the operator can regain control of the aircraft.
- If the communication can not be reestablished during the entire process of auto return, the aircraft will fly back to the take-off point (When the remote controller is powered off, the failsafe auto return is triggered by default.)

## After-sale Service

All of Chase products carry after-sale service guarantee, if you have any problems or questions when using our product, please contact UPair authorized distributors or UPair Customer Service.

Our website: [www.upair.net](http://www.upair.net)

Skype: [UPair\\_carl](https://www.skype.com/user/UPair_carl)

Email: [upair\\_bj@163.com](mailto:upair_bj@163.com)